

**699AP 699DP**

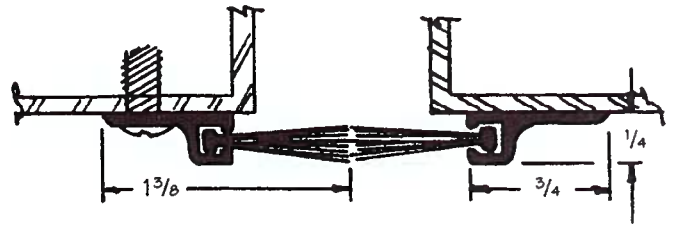

**107ANY, 107ANDY, 107AGNY**

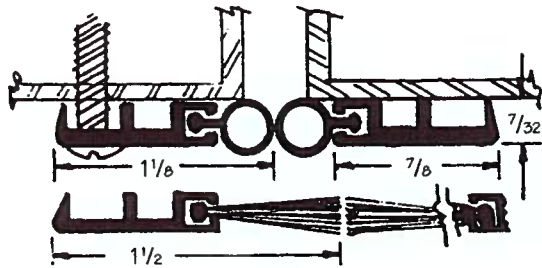

**240AN  
241AP**

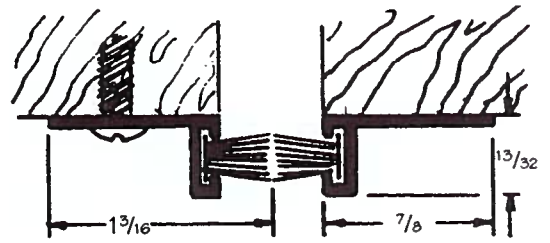

**599AP 599DP 599GP**

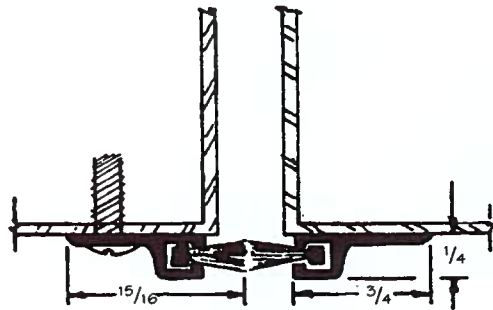

**99AP 99DP 99GP**

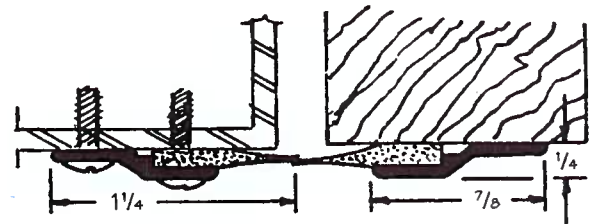

**98AN 98DN 98GN**

(Used when gap varies)

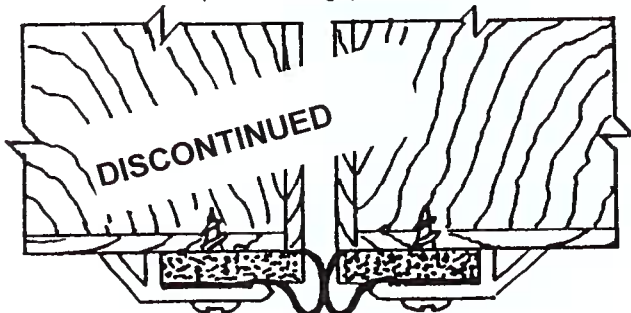

**810AFN, 810ADFN, 810AGN**

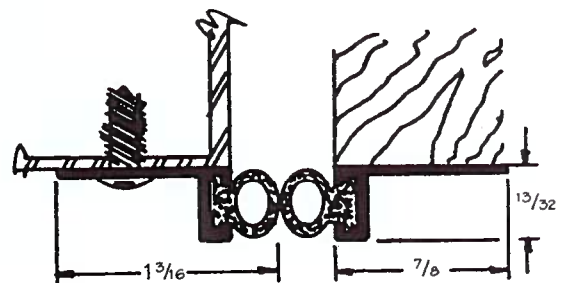

**599AV 599DV 599GV**

### MATERIAL DESIGNATIONS

A Aluminum	B Bronze	B Architectural Bronze	D Dark Brown Anodized or Paint
E EPDM-Rubber Polymer	F Felt	G Gold	N Solid or Closed Cell Neoprene
P Pile	SS Stainless Steel	V Vinyl	Z Zinc

# Double Door Equipment

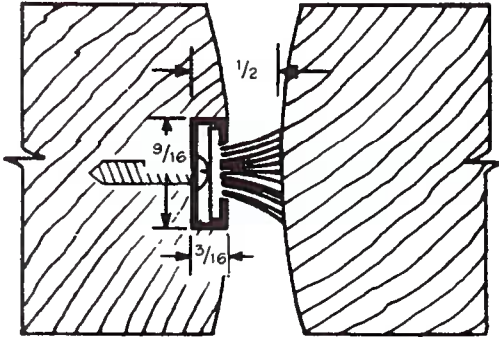

**97AP**

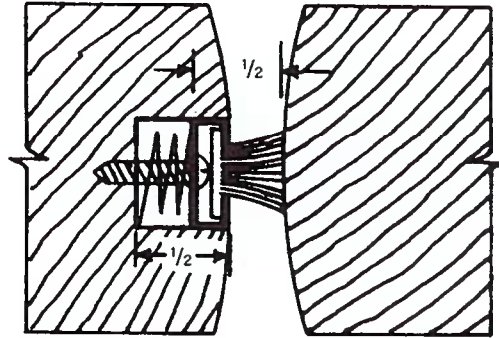

**97AS**  
Springs for adjustment,  
1/2" maximum.

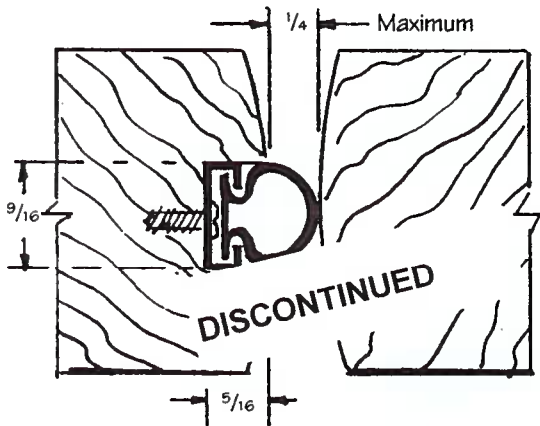

**12AV**

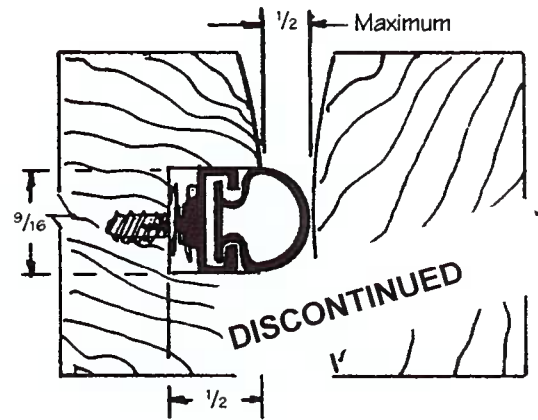

**92AES**  
Springs for adjustment,  
1/2" maximum.

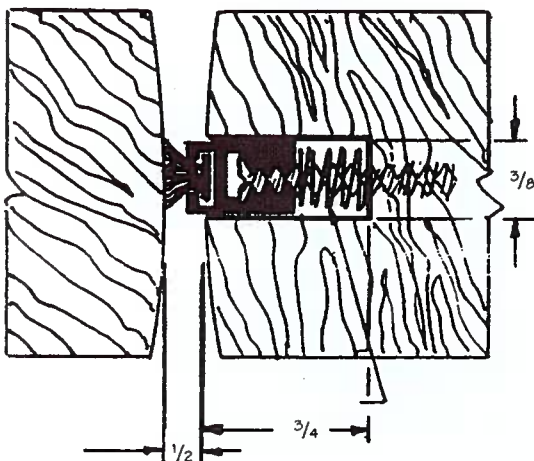

**86P**

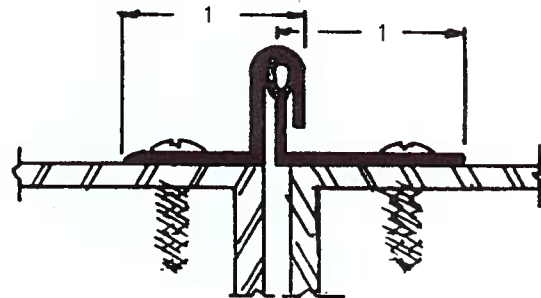

**34AV, 35A**

## MATERIAL DESIGNATIONS

A Aluminum	B Bronze	B Architectural Bronze	D Dark Brown Anodized or Paint
E EPDM-Rubber Polymer	F Felt	G Gold	N Solid or Closed Cell Neoprene
P Pile	SS Stainless Steel	V Vinyl	Z Zinc

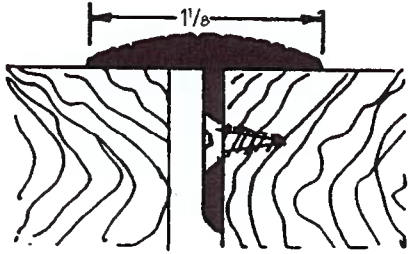

96A 96D 96G

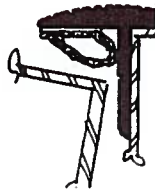

(Shown 2/3 of actual size with 116 silicone seal)

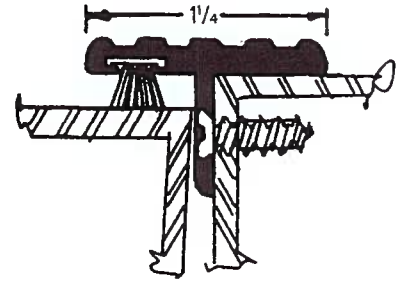

95AP 95DP 95GP

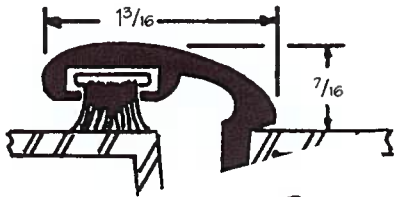

DISCONTINUED



93AP 93DP

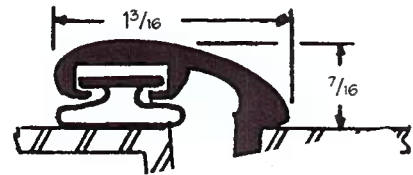

DISCONTINUED



93AE 93DE

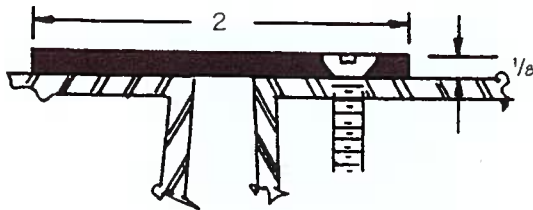

94A 94D

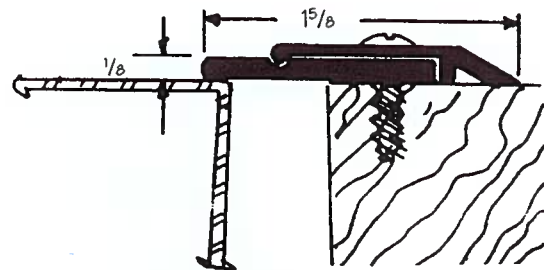

809AN, 809ADN, 809BN, 809GN

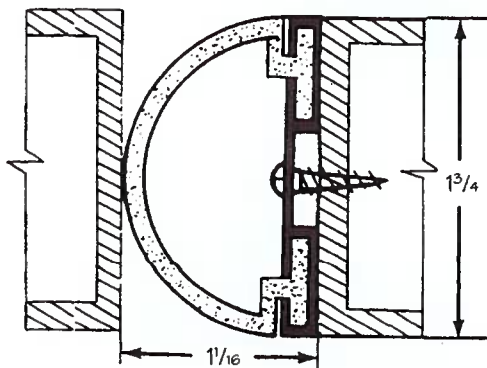

805AV

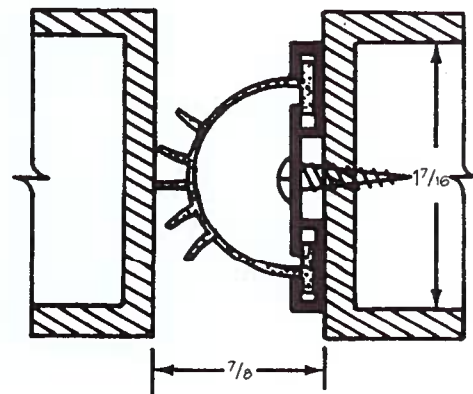

13AV

### MATERIAL DESIGNATIONS

A Aluminum	B Bronze	B Architectural Bronze	D Dark Brown Anodized or Paint
E EPDM-Rubber Polymer	F Felt	G Gold	N Solid or Closed Cell Neoprene
P Pile	SS Stainless Steel	V Vinyl	Z Zinc